

SIGN	DATE	DESCRIPTION	APPROVER
			Tony

THIS IS CAD DRAWING, DO NOT REVISE MANUALLY!!!

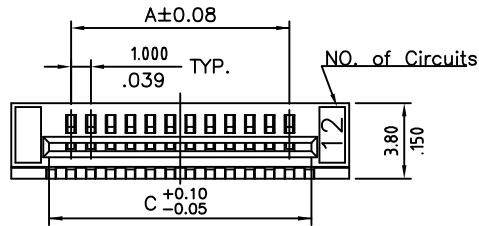

Circuits	Dimension			Circuits	Dimension		
	A	B	C		A	B	C
03	2.00(.079)	8.00(.315)	4.10(.161)	18	17.00(.670)	23.0(.905)	19.10(.752)
04	3.00(.118)	9.00(.354)	5.10(.201)	19	18.00(.709)	24.0(.945)	20.10(.791)
05	4.00(.157)	10.0(.393)	6.10(.240)	20	19.00(.748)	25.0(.984)	21.10(.831)
06	5.00(.197)	11.0(.433)	7.10(.280)	21	20.00(.787)	26.0(1.024)	22.10(.870)
07	6.00(.236)	12.0(.472)	8.10(.319)	22	21.00(.827)	27.0(1.063)	23.10(.909)
08	7.00(.275)	13.0(.512)	9.10(.358)	23	22.00(.866)	28.0(1.102)	24.10(.949)
09	8.00(.315)	14.0(.551)	10.10(.398)	24	23.00(.905)	29.0(1.142)	25.10(.988)
10	9.00(.354)	15.0(.590)	11.10(.437)	25	24.00(.945)	30.0(1.181)	26.10(1.028)
11	10.00(.393)	16.0(.630)	12.10(.476)	26	25.00(.984)	31.0(1.220)	27.10(1.067)
12	11.00(.433)	17.0(.670)	13.10(.516)	27	26.00(1.024)	32.0(1.260)	28.10(1.106)
13	12.00(.472)	18.0(.709)	14.10(.555)	28	27.00(1.063)	33.0(1.300)	29.10(1.146)
14	13.00(.512)	19.0(.748)	15.10(.594)	29	28.00(1.102)	34.0(1.339)	30.10(1.185)
15	14.00(.551)	20.0(.787)	16.10(.634)	30	29.00(1.142)	35.0(1.378)	31.10(1.224)
16	15.00(.590)	21.0(.827)	17.10(.673)	31	30.00(1.181)	36.0(1.417)	32.10(1.263)
17	16.00(.630)	22.0(.866)	18.10(.713)	32	31.00(1.220)	37.0(1.457)	33.10(1.303)

SPECIFICATIONS

RATINGS

Current Rating: 0.5A
Voltage Rating: 100V AC(r.m.s.)
Temperature Range: -25°C ~ +85°C
Contact Resistance: <30mΩ
Insulation Resistance: >500MΩ
Dielectric Withstanding Volt: 500V AC for 1 min

MATERIAL:

Insulation: Nylon 6T
Color: Nature
Contact: Phosphor Bronze
Plating: 120u" Tin over 30u" Nickel
Flammability: UL94V-0
Packaging: Tube

RoHS Compliant

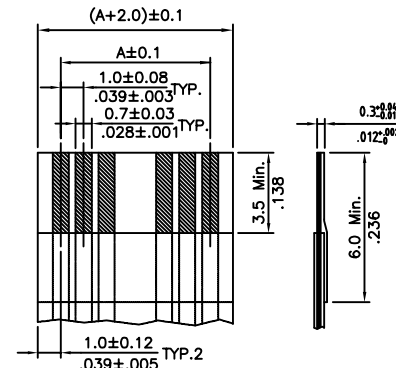
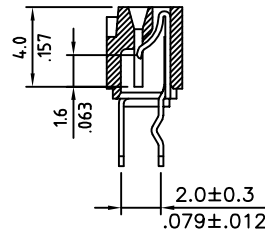
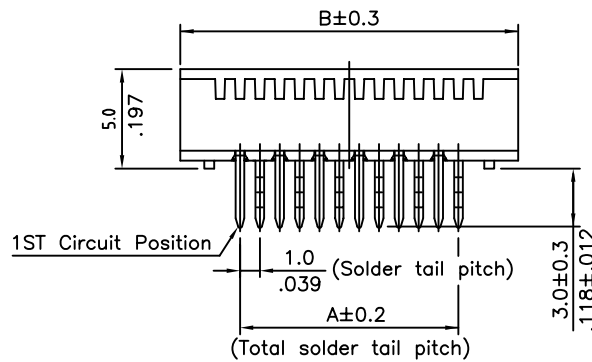

* ACCOMMODATED FFC

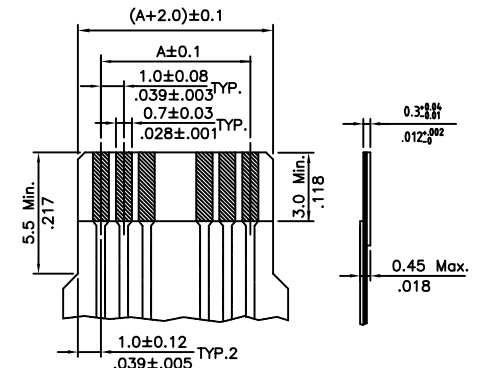

* ACCOMMODATED FPC

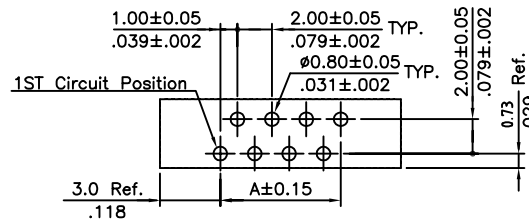

Recommended P.C. Board Layout

THESE DRAWINGS AND SPECIFICATIONS ARE THE PROPERTY OF ON-SHORE TECHNOLOGY, INC. AND SHALL NOT BE REPRODUCED, COPIED OR USED IN ANY MANNER WITHOUT THE PRIOR WRITTEN CONSENT OF ON-SHORE TECHNOLOGY, INC.



TITLE	FPC100L Series - 1.00mm LIF FFC/FPC vertical connector, upside contact						
PART NO.	FPC100LXXVTSTU (xx-number of circuits)	DWG NO.	FPC100LXXVTSTU.DWG				
APPROVED	CHECKED	DESIGNED	DRAWN	4050		Tolerance	
Alex 2007.09.28	David 2007.09.28	Eisley 2007.09.28	Sandy 2007.09.28				
						UNIT: mm/inch	
						SCALE: NONE	
				SHEET: 01/02		REV: A	